



**TWO-PHASE  
HYBRID STEPPER MOTOR DRIVER**

**Model: 2L542**

**Features**

- \* Patented technology
- \* Low cost , good high-speed torque
- \* Supply voltage up to +50VDC, current output up to 4.2A peak
- \* Optically isolated input signals, pulse frequency up to 400 KHz
- \* Automatic idle-current reduction
- \* 3-state current control for less motor heating
- \* 15 selectable resolutions in decimal and binary
- \* Suitable for 4,6,8 lead motors
- \* Stepping on upward or downward pulse edge (selectable)
- \* DIP switch current setting with 8 different value
- \* CW/CCW mode available (optional)
- \* Over-voltage and short-circuit protection
- \* Small size (118x75.5x33mm)

**1. Introduction**

2L542 is a low cost high performance microstepping driver based on most advanced technology in the world today. It is suitable for driving any 2-phase and 4-phase hybrid step motors. By using advanced bipolar constant-current chopping technique, it can output more speed and power from the same motor, compared with traditional technologies such as L/R drivers. Its 3-state current control technology allows coil currents to be well controlled, with relatively small current ripple and therefore less motor heating.

**2. Applications**

Suitable for a wide range of stepping motors of Nema 17, 23 and 34, and usable for various kinds of machines, such as X-Y tables, labeling machines, laser cutters, engraving machines, and pick-place devices. Particularly useful in applications with low vibration, high speed and high precision are desired.

**3. Electrical and Mechanical Specifications****3.1 Electric Specifications ( $T_j = 25\_$ )**

Parameters	2L542			Unit
	Min.	Typical	Max.	
Output Current	0.54	-	4.2(RMS 3A)	Amps
Supply voltage	20	36	50	VDC
Logic signal current	7	10	16	mA
Pulse input frequency	0	-	400	Khz
Isolation resistance			500	MΩ

**3.2 Mechanical Dimensions (unit = mm, 1 inch = 25.4 mm)**

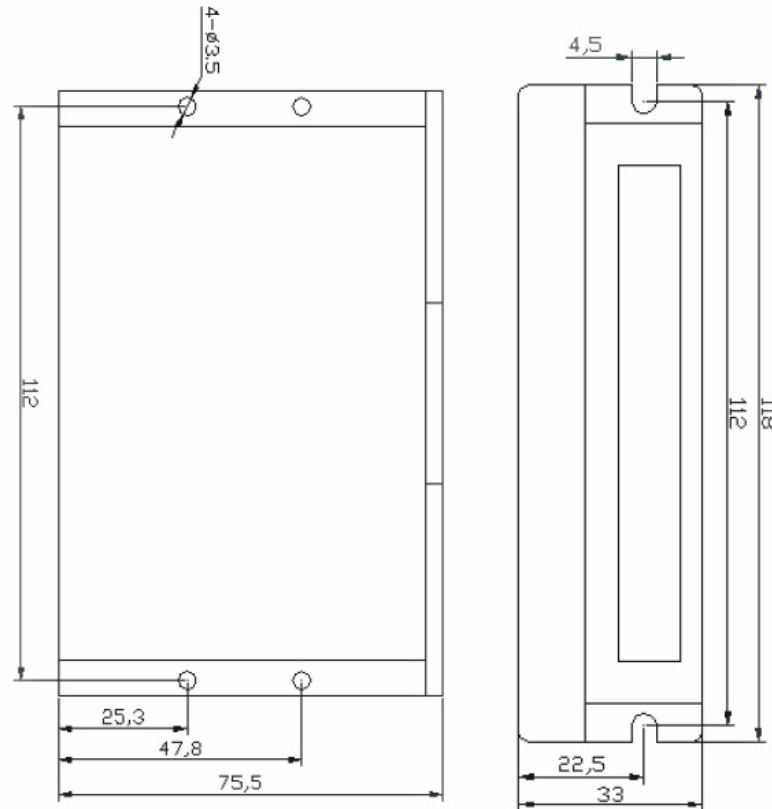

#### 4. Connection Configuration

##### 4.1 Connector P1 configuration

Signal	Functions
PUL+(+5V)	<u>Pulse signal</u> : in single pulse(pulse/direction) mode, this input represents pulse signal, effective for each upward – rising edge; in double pulse mode (pulse/pulse) this input represents clockwise(CW)pulse. For reliable response, pulse width should be longer than 1.5 $\mu$ s.
PUL- (PUL)	
DIR+ (+5V)	<u>Direction signal</u> : in single-pulse mode, this signal has low/high voltage levels, representing two directions of motor rotation; in double-pulse mode (set by inside jumper JMP1), this signal is counter-clock (CCW) pulse, effective on each rising edge. For reliable motion response, direction signal should be sent to driver 2 $\mu$ s before the first pulse in the reverse motion direction.
DIR- (DIR)	
ENA+ (+5V)	<u>Enable signal</u> : this signal is used for enable/disable, high level for enabling driver and low level for disabling driver. Usually left unconnected(enabled).
ENA- (ENA)	

##### 4.2 Connector P2 configuration

Pin No.	Signal	Functions
1	Gnd	DC power ground
2	+V	DC power supply, +18VDC - +50VDC, Including voltage fluctuation and EMF voltage.
3, 4	Phase A	Motor coil A (leads A+ and A-)
5, 6	Phase B	Motor coil B (leads B+ and B-)

**5. Setting Driver Output Current and Microstep Resolution****5.1 Current Setting**

DIP Setting for current during motion:

Peak current	RMS	SW1	SW2	SW3
1.00A	0.71A	on	on	on
1.46A	1.04A	off	on	on
1.91A	1.36A	on	off	on
2.37A	1.69A	off	off	on
2.84A	2.03A	on	on	off
3.31A	2.36A	off	on	off
3.76A	2.69A	on	off	off
4.20A	3.00A	off	off	off

**5.2 Microstep Resolution Selection**

Microstep resolution is set by SW5, 6, 7, 8 of the DIP switch as shown in the following table:

Microstep	ustep/rev.(for 1.8°motor)	SW5	SW6	SW7	SW8
2	400	Off	On	On	On
4	800	On	Off	On	On
8	1600	Off	Off	On	On
16	3200	On	On	Off	On
32	6400	Off	On	Off	On
64	12800	On	Off	Off	On
128	25600	Off	Off	Off	On
5	1000	On	On	On	Off
10	2000	Off	On	On	Off
20	4000	On	Off	On	Off
25	5000	Off	Off	On	Off
40	8000	On	On	Off	Off
50	10000	Off	On	Off	Off
100	20000	On	Off	Off	Off
125	25000	Off	Off	Off	Off

**6. Typical Wiring Diagram**

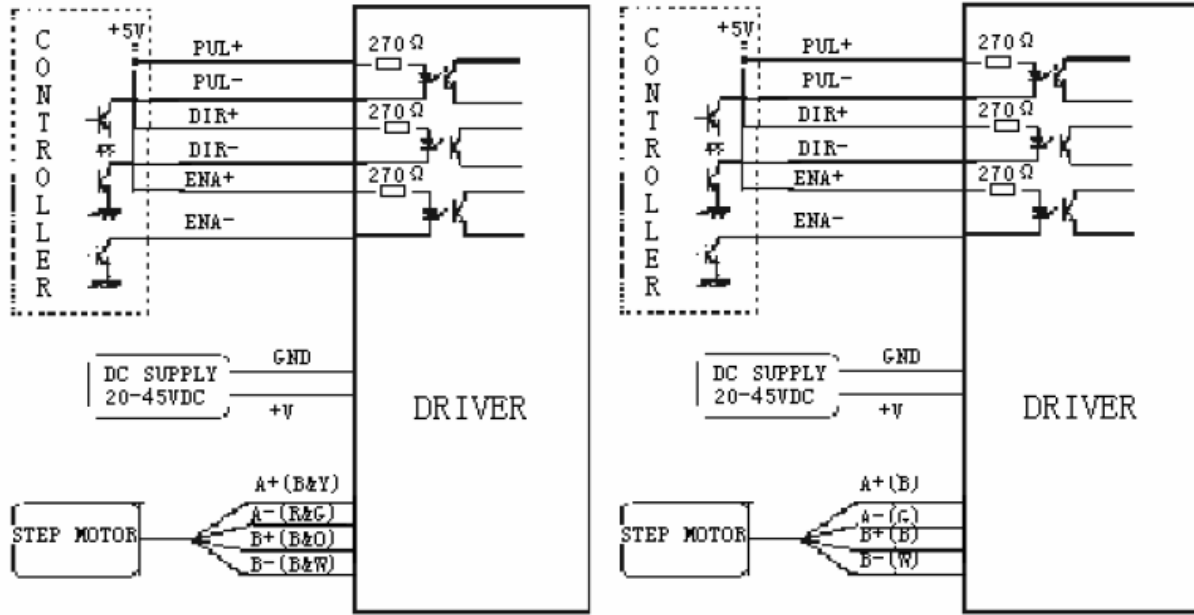

PARALLEL CONNECTION TO MOTOR

SERIES CONNECTION TO MOTOR

Remark: B (blue) Y (yellow) R (red) G (green) B (brown) O (orange) B (black) W (white)